

### Storage requirements

Macrolux® crates or sheets should be stored in warehouse areas not exposed to direct heat or light which could make the removal of protective film difficult. Supported, sloped stacking is recommended, but sheets may be stacked up to 3' high on a flat, even, supported surface.

### Protective film

All Macrolux® panels are supplied with a protective PE film which should be kept on until the panel is fastened. The U.V. protected side is to be faced towards the sun and is marked with a white printed film, clear, or light blue film with a sticker saying Macrolux® co-extruded thermoglaing.

### Fabrication

Macrolux® will not crack or split when cut or drilled. Macrolux® may be cut using a circular saw with a fine tooth blade or with a razor knife cut on both sides of the material. Compressed air may be used to remove dust from the channels.

### Installation

Stiff fixing by means of adhesive or putty is to be avoided. If using sealants, contact your Macrolux® USA distributor for recommended sealants.

Exposed top and bottom ends of a sheet must always be sealed by means of an adhesive aluminum tape to prevent dust and dirt penetrating inside the ribs. A proper polycarbonate "U" profile must then be installed to protect the tape.

Glazing sheets should be joined by Macrolux® extruded polycarbonate profiles and be installed with their protective U.V. stabilized surface towards the exterior. Consult with your local Macrolux® Distributor for approved systems.

The use of horizontal bars should be avoided. Instead, order Macrolux® in the proper length (up to 39 ft.) For proper application of Macrolux® in roofing conditions, a slope of at least 5° is required.

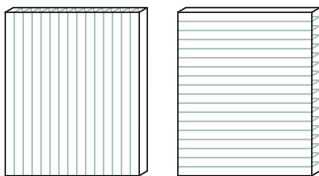

Extruded ribs shall be installed in a vertical direction for drainage.

Correct

Incorrect

### Installation

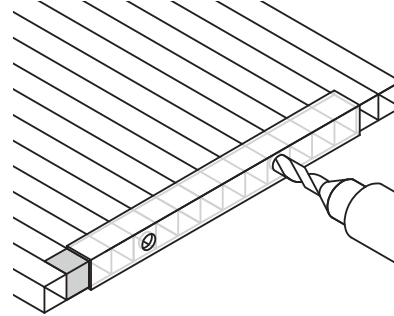

It is advisable to drill small weep holes every 12 inches along the bottom "U" profile for condensation drainage.

\*To avoid damaging the aluminum tape on the sheets, drill holes on Polycarbonate "U" Profiles before installation.

### Proper expansion

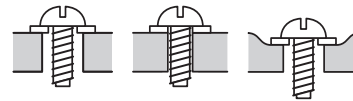

Allow for proper expansion in all drilled holes. Pre-drill screw holes 1/4" larger than screw diameter. Do not drill within 1 1/2" from the edge of the Macrolux® sheet. When fastening screws, do not tighten below the surface of the panel.

### Fastening

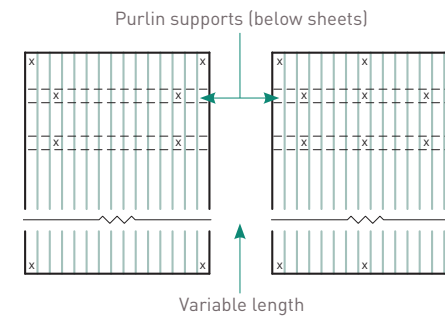

For proper point fastening, 1" neoprene bonded washers should be used with screws.

#### 48" Width

48 inch wide sheets should be fastened to supports at all four corners, and at points 6" in from the edges of each purlin support.

#### 72" Width

72 inch wide sheets should be fastened to supports at all four corners, and at points 6" in from the edges of each purlin support and in the center of the purlin supports.

### Cleaning

Macrolux® should be protected from abrasion by the installer. After installation, panels should be washed with mild soap or detergent and lukewarm water using only a clean sponge or soft cloth, then rinsed with clean water. Fresh paint, grease, and smeared glazing compounds may be removed before drying by rubbing lightly with a good grade of naphtha or isopropyl alcohol followed by a final wash with mild soap or detergent and final rinse.

		TWIN				TRIPLE			X-STRONG	FIVE	FIVE M		
Sheet thickness	mm	4	6	8	10	6	8	10	16	16	25	32	35
	in	5/32	1/4	5/16	3/8	1/4	5/16	3/8	5/8	5/8	1	1 1/4	1 3/8
Minimum bending radius	in	24	36	48	60	36	48	60	95	95	148	189	207

### Resistance of polycarbonate to chemical agents

Polycarbonate panels are resistant to some chemicals and products and nonresistant to others. Resistance can be effected by the chemicals concentration, duration of exposure, degree of pressure and temperature at time of contact. Check with your local Macrolux® USA distributor for complete recommendations.

### Thermal expansion

Allow for thermal expansion during installation at a rate of 1/8" per 3 feet at 100° temperature differentials in both width and length of the sheet. Bronze panels will require an additional 30% space.

### Bending Radll

Macrolux® panels can be readily cold formed to many bending radii and can be fabricated on site to precise dimensions. It is important to avoid over tensing of the sheet, therefore, the minimum bending radius must be 150 times the thickness of the panel. Minimum Bending Radius = Ft./1 inch.

### Impact resistance

Able to withstand extreme abuse, its impact strength is 200 times greater than glass and 10 times greater than acrylic. Among the thermostatic products used in the building industry, Macrolux® co-extruded thermoglazing has the highest impact resistance. You can be assured that from transport to installation, Macrolux® will maintain its durability. Even when exposed to elevated temperatures over a long period of time, it will maintain its structural integrity. On-site, it will not crack or splinter, assuring you a high degree of safety.

### Recommended loading

The charts below are valid only when the following conditions are followed:

- Correct calculation of expansion in order to provide for the necessary allowance in the framing. The thermal expansion coefficient is 0.0000375 in/in °F.
- Install the sheets with the ribs running vertically. For bent applications, the ribs should bend, following the arch in the sheet.
- Washers and sealing materials must be compatible with polycarbonate.

Wall structure	Thickness		LOAD (lb/ft²)													
	mm	in	2' width				4' width				6' width					
			15	30	45	60	15	30	45	60	15	30	45	60		
Maximum deflection 1"																
Twin, triple	6	¼	Length (in)	25	21	20	15	18	16	-	-	18	-	-	-	
	8	⅕		31	22	18	16	21	17	-	-	20	-	-	-	
	10	⅜		98	34	26	23	27	21	19	17	24	21	18	-	
Five	16	¾		118	66	36	30	32	24	21	18	29	23	20	18	
	25	1		465	150	126	120	44	32	29	26	37	29	26	19	
Five M	32	1-¼		465	197	146	110	50	37	31	28	40	32	29	25	
	35	1-⅝		465	236	157	118	58	42	34	31	44	33	30	26	
Maximum deflection 2"																
Twin, triple	6	¼		Length (in)	66	27	23	16	22	17	-	-	20	-	-	-
	8	⅕			65	33	24	18	25	19	-	-	22	-	-	-
	10	⅜			132	67	45	36	34	26	23	21	26	23	20	-
Five	16	¾			177	98	54	41	41	30	26	23	35	27	23	19
	25	1			465	164	146	133	70	43	37	32	44	35	31	20
Five M	32	1-¼			465	217	162	134	88	50	40	36	49	39	34	27
	35	1-⅝			465	297	189	148	108	62	47	41	55	42	37	28
Maximum deflection 3"																
Twin, triple	6	¼	Length (in)		106	32	26	17	26	18	-	-	21	14	-	-
	8	⅕			98	44	30	19	29	21	-	-	23	16	12	-
	10	⅜			165	100	63	49	40	31	27	25	28	25	21	14
Five	16	¾			236	130	71	51	50	36	31	28	40	31	25	20
	25	1			465	177	165	146	96	54	44	38	51	41	36	21
Five M	32	1-¼			465	236	177	157	126	62	48	44	58	45	39	28
	35	1-⅝			465	357	221	177	157	82	60	50	65	50	44	29

The information contained in these charts has been drafted on the basis of our best knowledge. Macrolux USA reserves the right to change specifications and data, without notice, if deemed necessary in the evolution of its products. It is the sole responsibility of the customer to confirm with their own architect, engineer or other professional consultants that the materials offered for sale meet the requirements and specifications of the particular project and use for which they are being purchased.

For complete information regarding thermal expansion or required supporting structure for your specific application, contact Macrolux USA.

